

# MD2278 Microstepping Driver

## 1. Introduction

The MD2278 is a high performance and low noise microstepping driver based on pure-sinusoidal current control technology. It's suitable for driving 2-phase and 4-phase hybrid stepping motors. By using advanced bipolar constant-current chopping technique, the MD2278 can output more torque than other drivers at high speed. The microstep capability allows stepping motors to run at higher smoothness, less vibration and lower noise. Its pure-sinusoidal current control technology allows coil current to be well controlled with relatively small current ripple, therefore smaller motor noise and less motor heating can be achieved.



## 2. Features

- High quality, cost-effective
- Low motor & driver heating
- Supply voltage up to 220VAC
- Output current up to 7.8A(5.57 ARMS)
- TTL compatible and opto-isolated inputs
- Automatic idle-current reduction
- Input frequency up to 400KHz
- 16 microstep resolutions selectable
- Suitable for 2-phase and 4-phase stepping motors
- DIP switch microstep & current settings
- Support PUL/DIR & CW/CCW modes

## 3. Applications

Suitable for large and medium automation machines and equipments, such as engraving machines, labeling machines, cutting machines, laser phototypesetting systems, plotting instruments, NC machines, pick-place devices, and so on. Particularly adapt to the applications desired with low noise, low vibration, high speed and high precision.

## 4. Specifications

### Electrical Specifications (T<sub>j</sub> = 25°C)

Parameters	MD2278			Unit
	Min	Typical	Max	
Output current	0.42 (0.3A RMS)	-	7.8	A
Supply voltage	80	180	220	VAC
Logic signal current	7	10	16	mA
Pulse input frequency	0	-	400	Khz
Isolation resistance	500			MΩ

### Operating Environment and Other Specifications

Cooling	Natural Cooling or Forced cooling	
Operating Environment	Environment	Avoid dust, oil fog and corrosive gases
	Ambient Temperature	0°C — 50°C
	Humidity	40%RH — 90%RH
	Operating Temperature	70°C Max
	Vibration	5.9m/s <sup>2</sup> Max
Storage Temperature	-20°C — 65°C	
Weight	Approx. 1.16 kg (41 oz)	

### Mechanical Specifications (unit: mm, 1 inch = 25.4 mm)

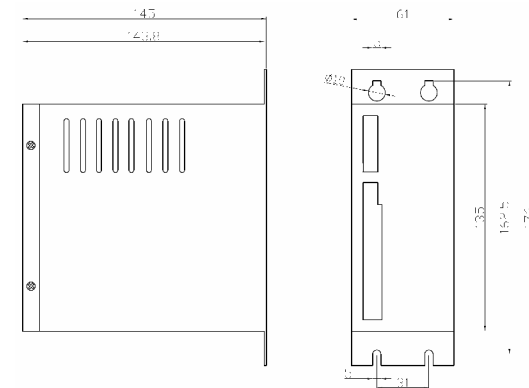

Figure 1: Mechanical specifications

## 5. Pin Assignment and Description

The MD2278 has two connectors, connector P1 for control signals connections, and connector P2 for power and motor connections. The following tables are brief descriptions of the two connectors of the MD2278.

### Connector P1 Configurations

Pin Function	Details
PUL+(+5V)	<b>Pulse signal:</b> In single pulse (pulse/direction) mode, this input represents pulse signal, active at each rising edge; 4-5V when PUL-HIGH, 0-0.5V when PUL-LOW. In double pulse mode (pulse/pulse), this input represents clockwise (CW) pulse, active at high level. For reliable response, pulse width should be longer than 1.2μs. Series connect resistors for current-limiting when +12V or +24V used.
PUL-(PUL)	<b>DIR signal:</b> In single-pulse mode, this signal has low/high voltage levels, representing two directions of motor rotation; in double-pulse mode (set by SW5), this signal is counter-clock (CCW) pulse, active for high level. For reliable motion response, DIR signal should be ahead of PUL signal by 5μs at least. 4-5V when DIR-HIGH, 0-0.5V when DIR-LOW. Please note that motion direction is also related to motor-driver wiring match. Exchanging the connection of two wires for a coil to the driver will reverse motion direction.
DIR+(+5V)	<b>Enable signal:</b> This signal is used for enabling/disabling the driver. High level (NPN control signal, PNP and Differential control signals are on the contrary, namely Low level for enabling,) for enabling the driver and low level for disabling the driver. Usually left <b>UNCONNECTED (ENABLED)</b> .
DIR-(DIR)	<b>Alarm signal positive:</b> READY+ is an optocoupler output from open-collector circuit, maximum permitted input voltage is 30VDC; maximum output current 20mA. It generally can be serial connected to PLC input terminal.
ENA+(+5V)	Alarm signal negative.
ENA-(ENA)	
READY+	
READY-	

**Notes:** SW5 ON means CW/CCW (pulse/pulse) mode, and SW5 OFF means PUL/DIR mode.

### Connector P2 Configurations

Pin Function	Details
AC	AC power supply inputs. Recommend use isolation transformers with theoretical output voltage of 80 ~ 180 VAC, leaving room for power fluctuation and back-EMF.
AC	
A+, A-	Motor phase A.
B+, B-	Motor phase B.
PE	Ground terminal. Recommend connect this port to the ground for better safety.

## 6. Selecting Microstep Resolution and Driver Output Current

This driver uses a 9-bit DIP switch to set microstep resolution, motor operating current and control signal mode as shown in the following figure:

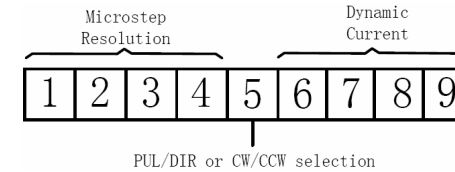

### Microstep Resolution Selection

Microstep resolution is set by SW1, 2, 3, 4 of the DIP switch as shown in the following table:

Steps/rev.(for 1.8°motor)	SW1	SW2	SW3	SW4
400	ON	ON	ON	ON
500	OFF	ON	ON	ON
600	ON	OFF	ON	ON
800	OFF	OFF	ON	ON
1000	ON	ON	OFF	ON
1200	OFF	ON	OFF	ON
1600	ON	OFF	OFF	ON
2000	OFF	OFF	OFF	ON
2400	ON	ON	ON	OFF
3200	OFF	ON	ON	OFF
4000	ON	OFF	ON	OFF
5000	OFF	OFF	ON	OFF
6000	ON	ON	OFF	OFF
6400	OFF	ON	OFF	OFF
8000	ON	OFF	OFF	OFF
10000	OFF	OFF	OFF	OFF

### Current Settings

The latter four bits (SW6, 7, 8, 9) of the DIP switch are used to set the dynamic current. Select a setting closest to your motor's required current.

**Dynamic Current Setting**

Peak current (A)	RMS (A)	SW6	SW7	SW8	SW9
0.45	0.32	OFF	OFF	OFF	OFF
0.63	0.45	OFF	OFF	OFF	ON
1.41	1.00	OFF	OFF	ON	OFF
1.88	1.34	OFF	OFF	ON	ON
2.33	1.66	OFF	ON	OFF	OFF
2.85	2.04	OFF	ON	OFF	ON
3.23	2.31	OFF	ON	ON	OFF
3.75	2.68	OFF	ON	ON	ON
4.26	3.04	ON	OFF	OFF	OFF
4.65	3.32	ON	OFF	OFF	ON
5.18	3.70	ON	OFF	ON	OFF
5.55	3.96	ON	OFF	ON	ON
6.15	4.39	ON	ON	OFF	OFF
6.60	4.71	ON	ON	OFF	ON
7.20	5.14	ON	ON	ON	OFF
7.80	5.57	ON	ON	ON	ON

**Notes:** Due to motor inductance, the actual current in the coil may be smaller than the dynamic current setting, particularly under high speed condition.

**Standstill Current**

The MD2278 has automatic idle-current reduction function. The current automatically be reduced to 60% of the selected dynamic current setting 0.2 second after the last pulse. Theoretically, this will reduce motor heating to 36% (due to  $P=I^2 \cdot R$ ) of the original value. If the application needs a different standstill current, please contact Leadshine.

**Control Signal Mode Setting**

SW5 is used for this purpose. SW5 ON means CW/CCW (pulse/pulse) mode, and SW5 OFF means PUL/DIR mode.

**7. Typical Connection**

A complete stepping system should include stepping motor, stepping driver, power supply and controller (pulse generator). A typical connection is shown as figure 2.

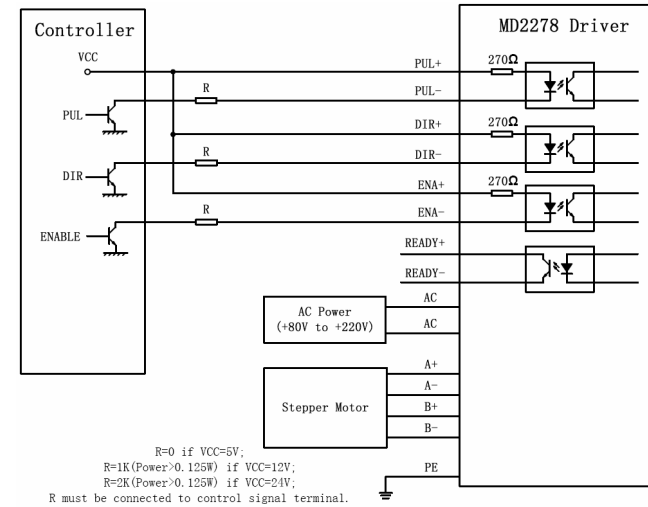

Figure 2: Typical connection